

aroTHERM split

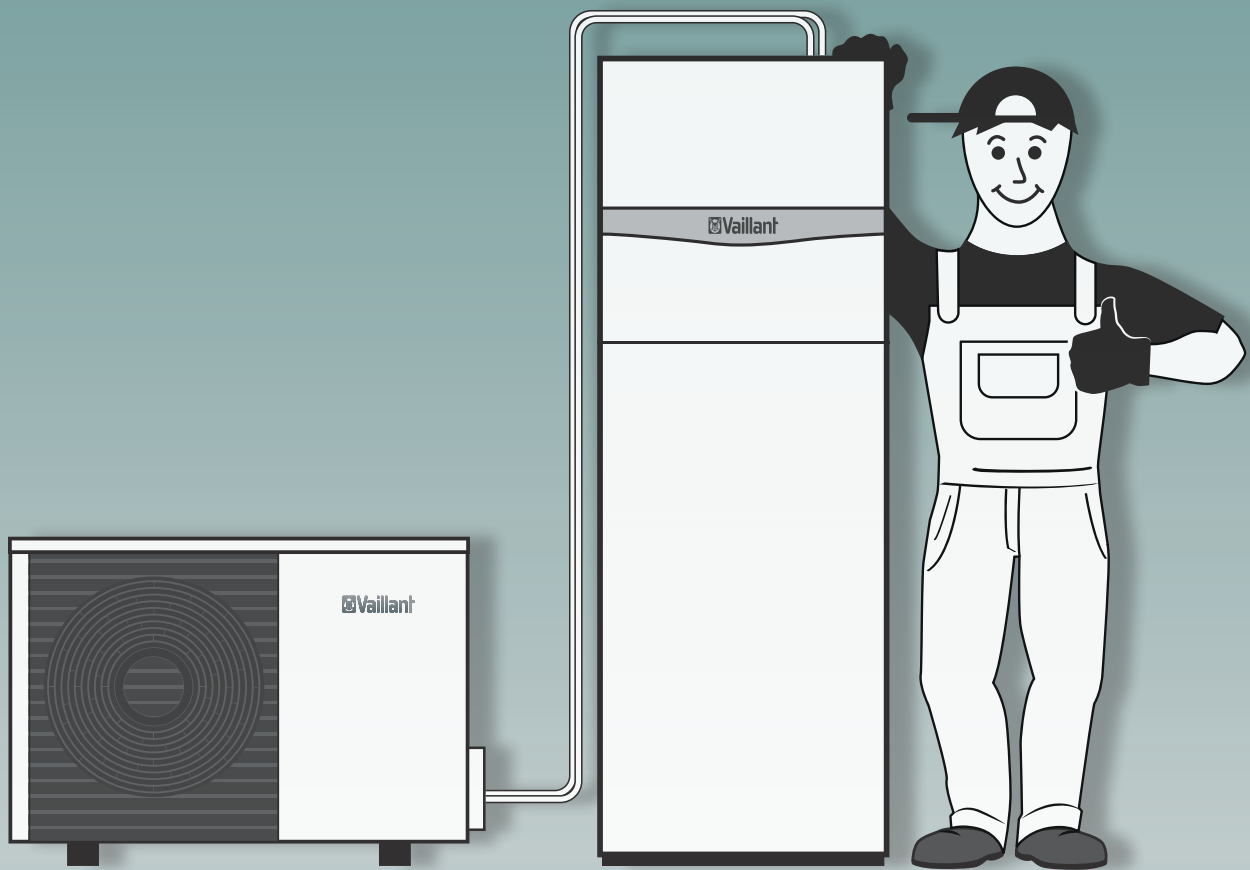

Important Note:

This quick guide shall support the professional installer in planning, installing and commissioning the appliance. It shall on no account replace or modify the installation, operating and maintenance instructions delivered with the appliance which always have to be observed.

The non-observance of the instructions delivered with the appliance can lead to malfunctions of the appliance and can result in death or serious injuries. Some characteristics of the appliance shown in this quick guide may vary from those of the most current series version. Vaillant shall not be held liable for any damages or injuries arising directly or indirectly from the use of this quick guide.

©All rights reserved. Vaillant, 2020.

Hint:

Follow the symbol to dedicated documents for more detailed information.



Hint:

Scan the QR code to download the digital version of this Quick Guide.





Get started quickly!

Your perfect installation with aroTHERM split step-by-step:

Plan your Work ...

- » Select the ideal aroTHERM split to fit your needs: performance, dimensions, sound 4
- » Find the perfect space for your installation: quiet, vented 7
- » Select the perfect domestic hot water and buffer storage 12
- » Dimension the expansion vessel 13
- » Select your system scheme (system components, hydraulics and wiring) 14
- » Decide on installation type to select required accessories (ground, wall, roof) 15
- » Tick your planning checklist 18

... work your Plan: Install the aroTHERM split system

- » Start with the hydraulic installation 19
- » Proceed to the power supply and eBUS connection 22
- » Connect the uniTOWER or hydraulic module 24
- » Commission the refrigerant circuit 27
- » Tick your installation checklist 28

... and start your System

- » Scan the QR code to easily set up the system 29
- » Just in case: Find remedies to error, status and maintenance codes 29

Find technical data...

- » aroTHERM split 30
- » uniTOWER, hydraulic module 31

Check the product installation manuals for further information.

We are here to help you!

Don't hesitate to contact us for further support:

Vaillant GmbH

Berghauser Str. 40 ■ D-42859 Remscheid
Tel. +492191 18 0 ■ Fax +492191 18 2810
info@vaillant.de ■ www.vaillant.de



Plan your work ...

Select the ideal aroTHERM split to fit your needs

Heating

--- VWL 35/5 ● VWL 75/5 - - - VWL 105/5 (230 V/400 V)
● VWL 55/5 - - - VWL 125/5 (230 V/400 V)

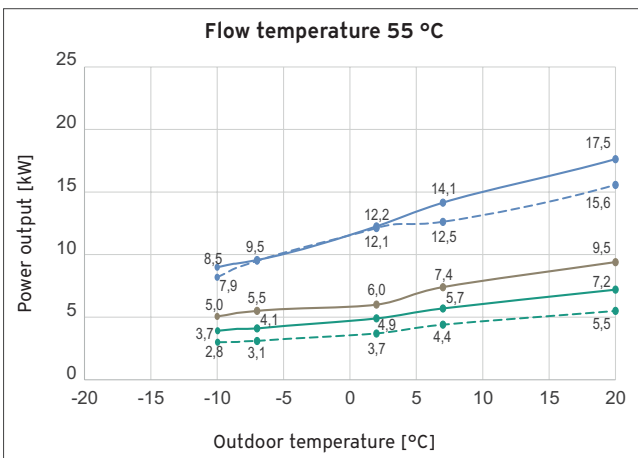
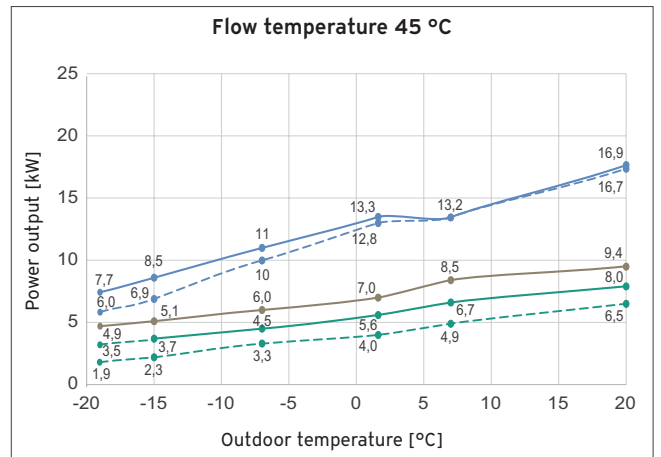
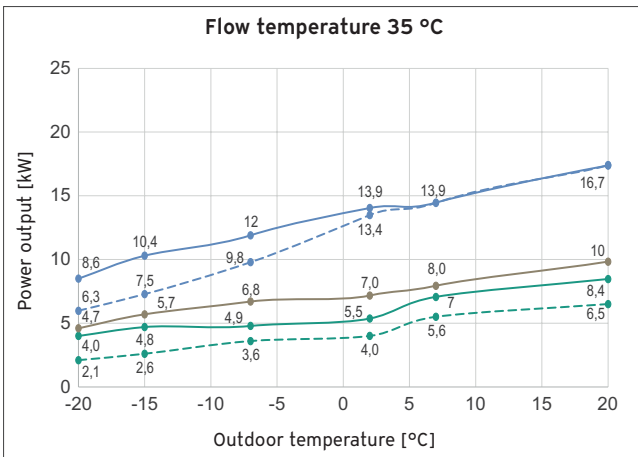

Cooling

● VWL 35/5 ● VWL 75/5 ● VWL 105/5 (230 V/400 V)
● VWL 55/5 - - - VWL 125/5 (230 V/400 V)

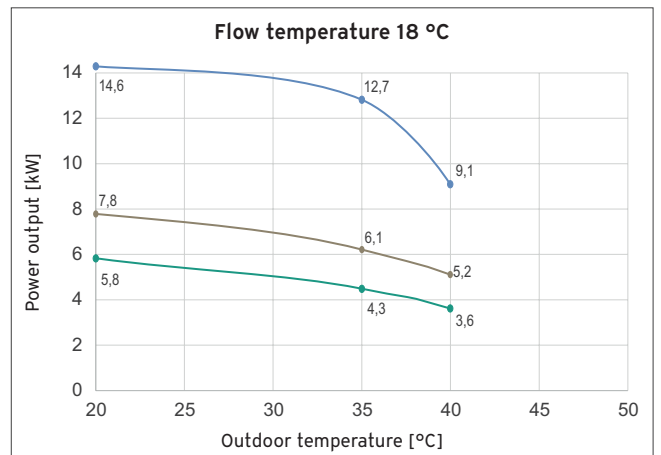
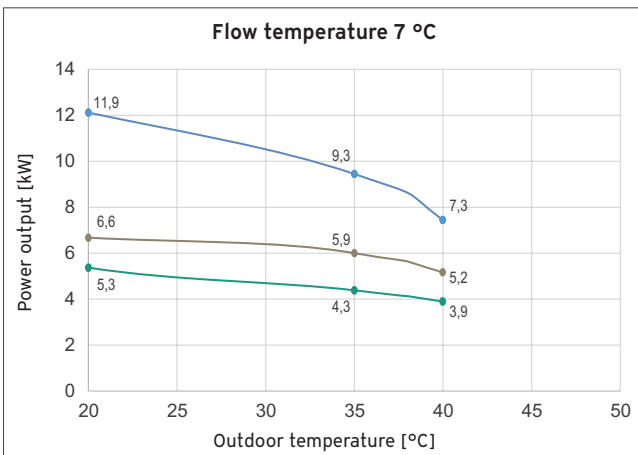

Product dimensions

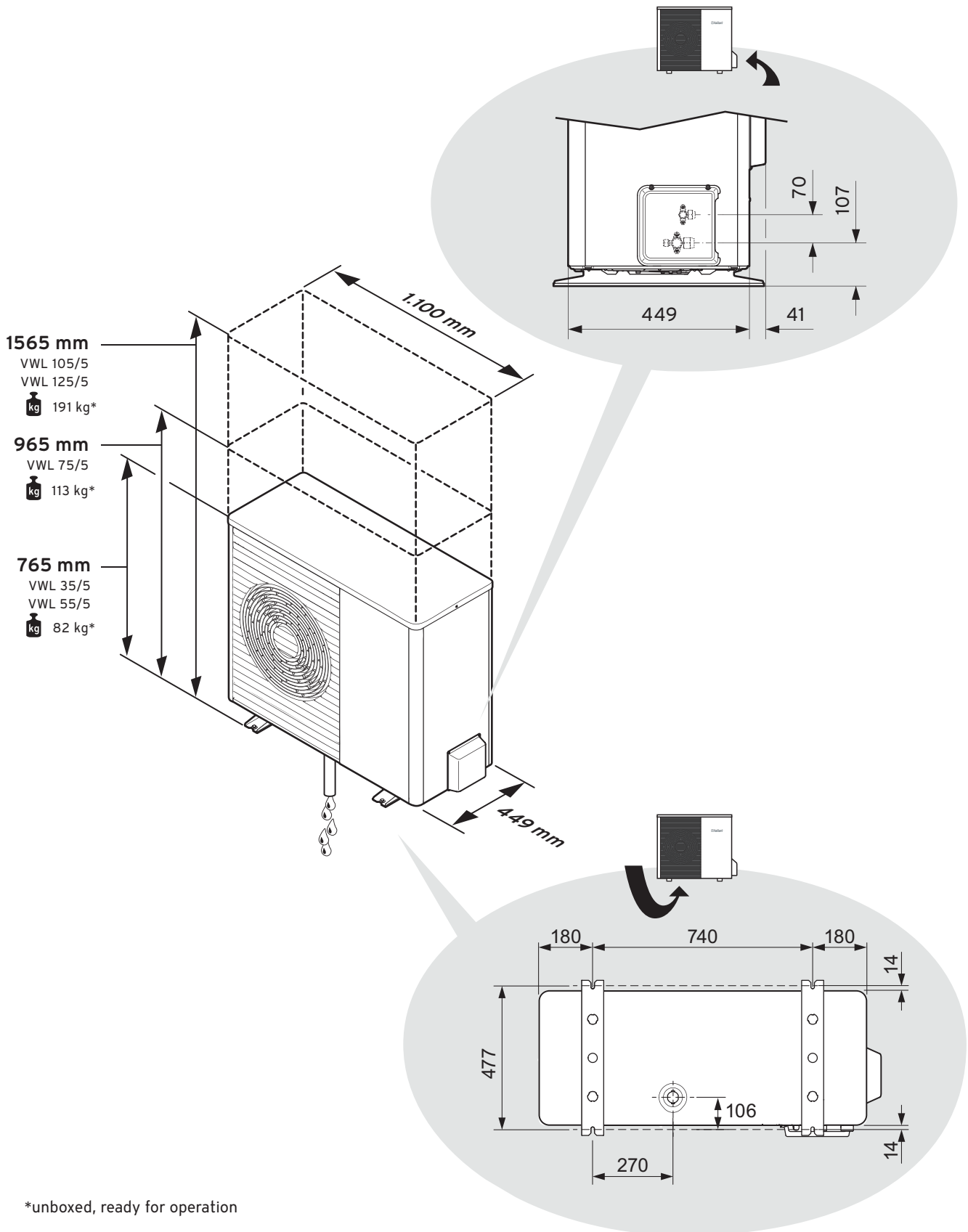

Sound pressure level

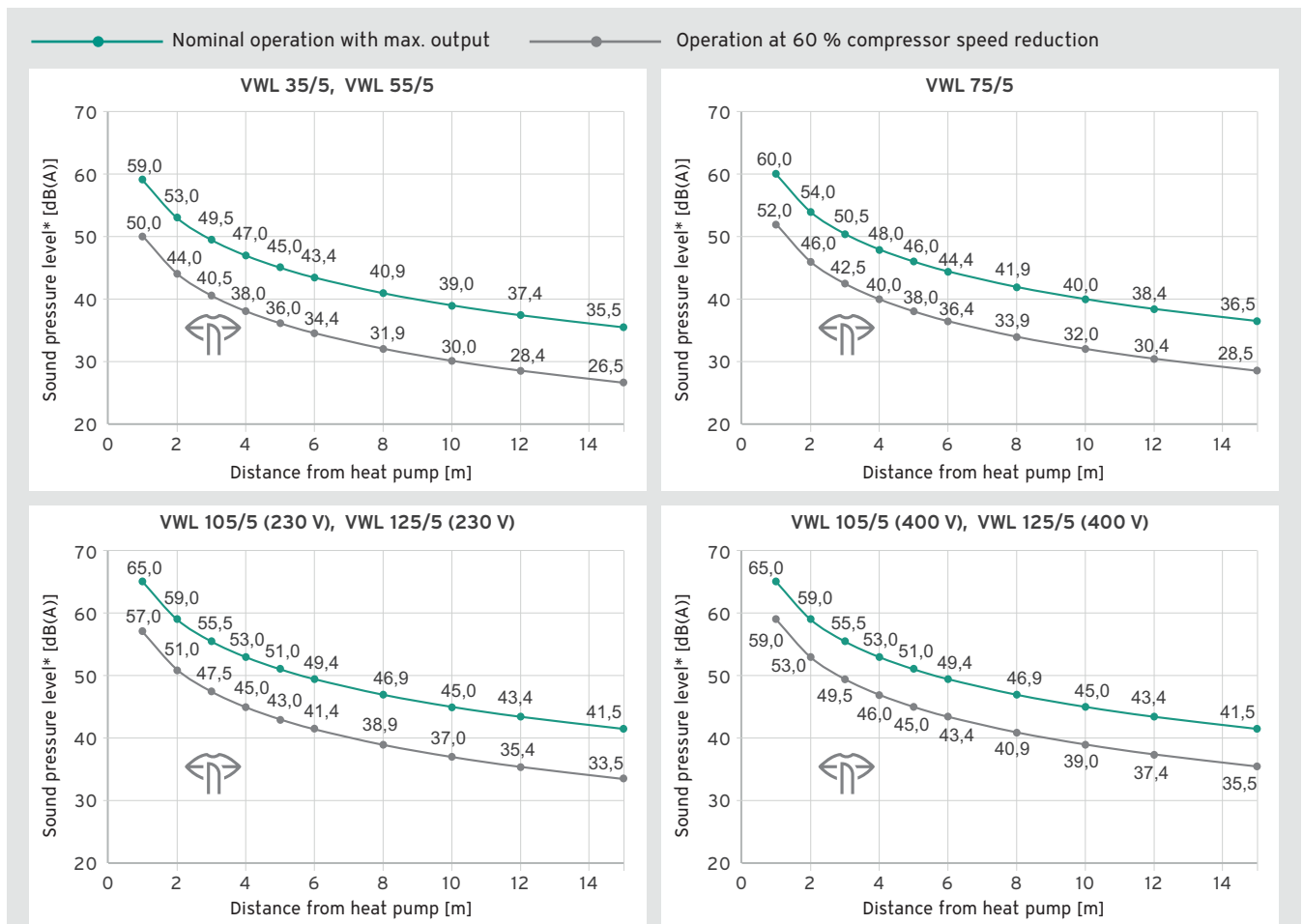

* Sound pressure level applicable to the following installation situations:

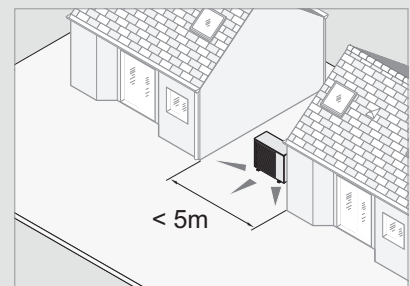
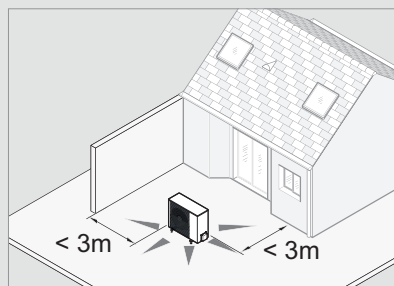
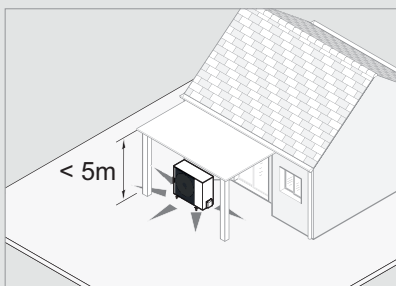

... this sound pressure level is **reduced** as follows:

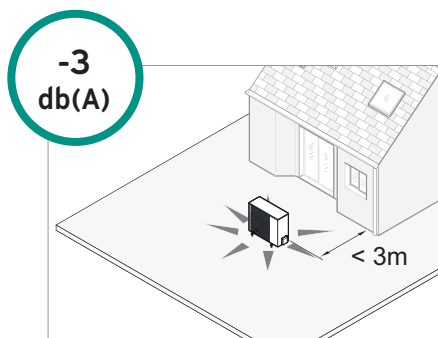

or

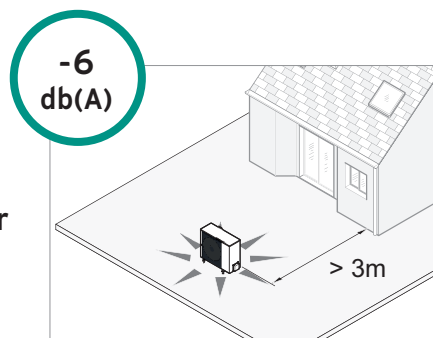

0020222099



Find the perfect space for your installation

A quiet space for your installation

Do! 

Don't 

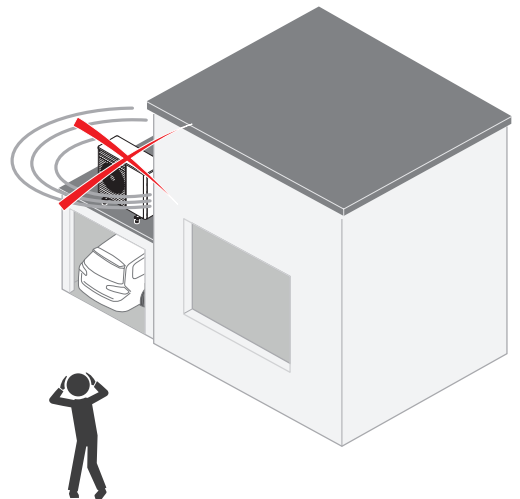
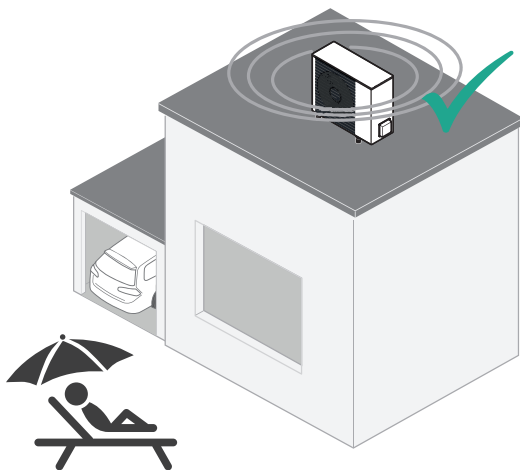
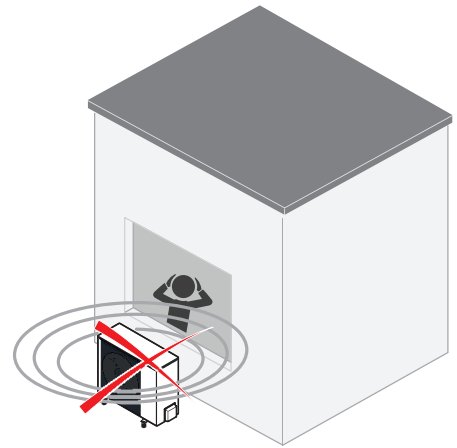
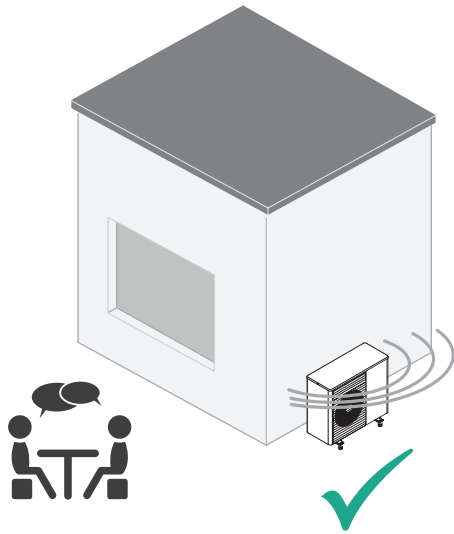

A vented space for perfect operation

Do! 

Don't 

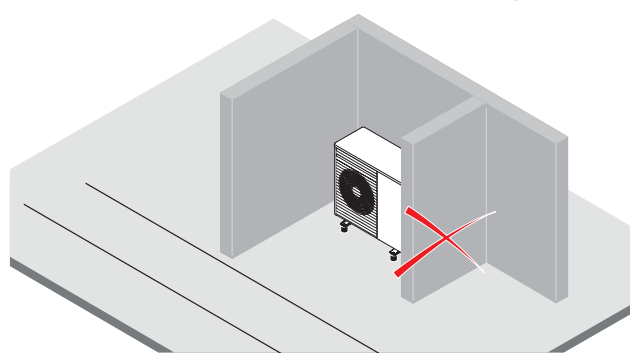
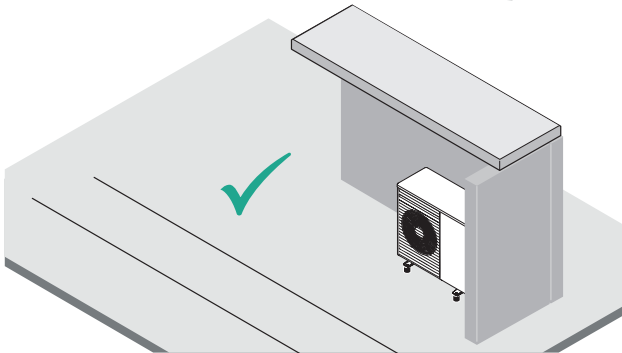
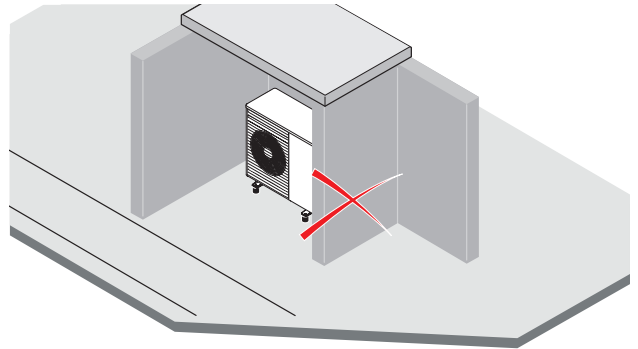
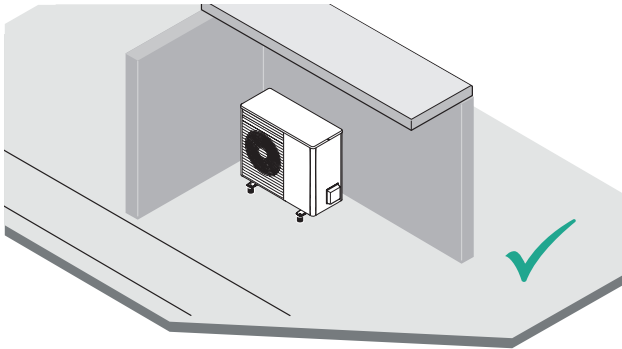

Minimum distances for flawless operation

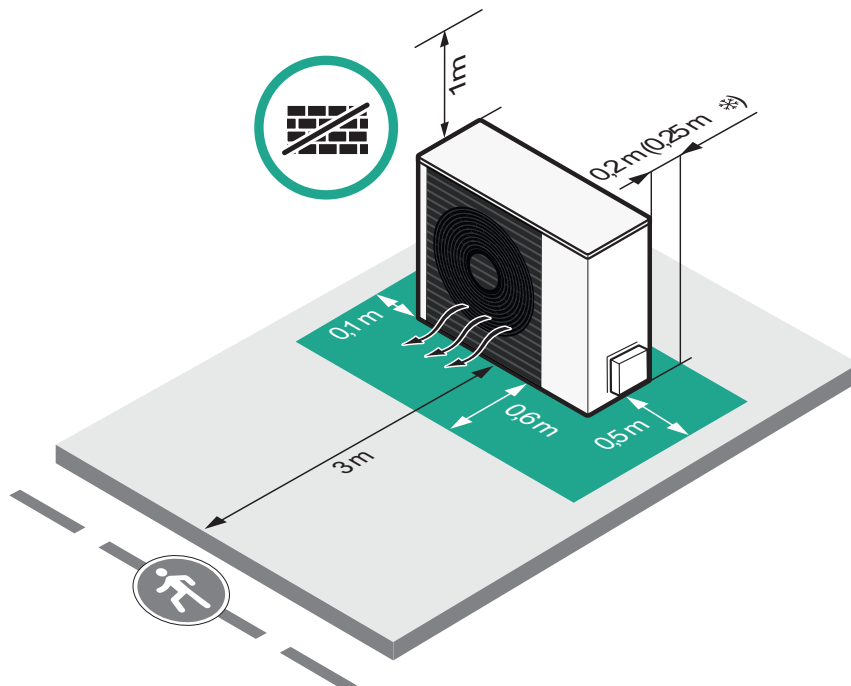

Install several aroTHERM split in one spot

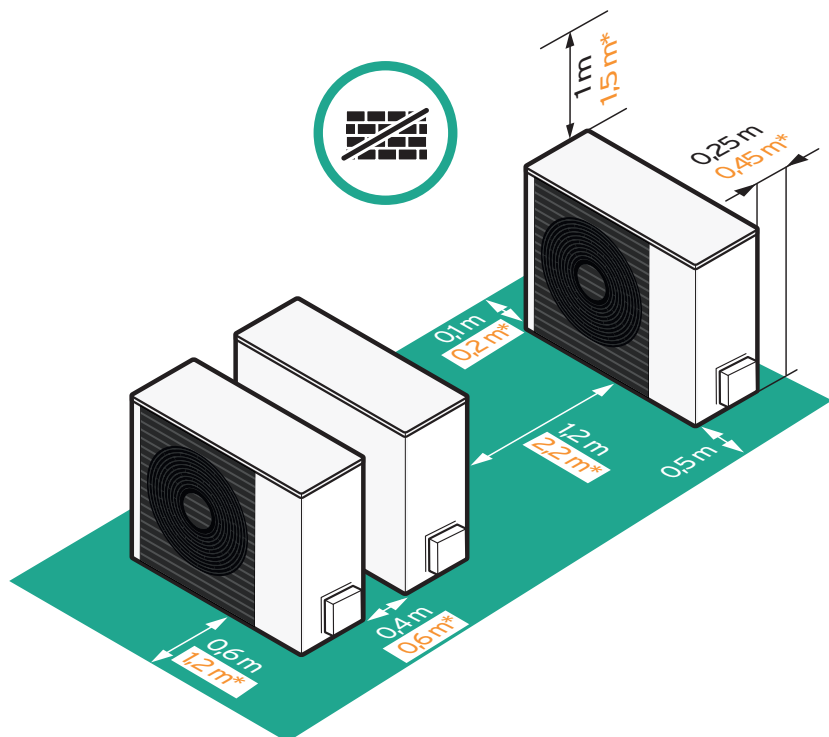
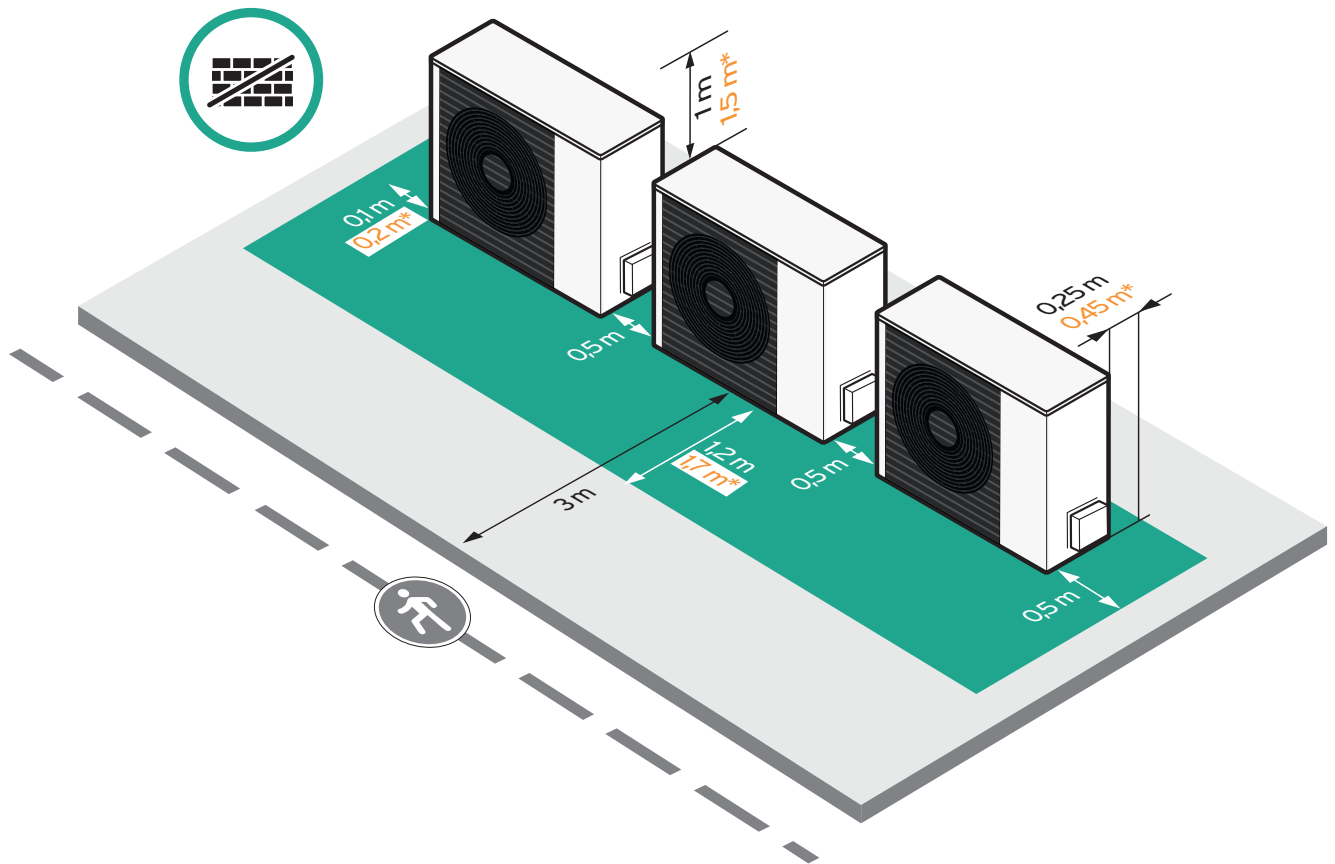

* VWL 105/5
VWL 125/5

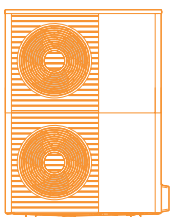

Install several aroTHERM split in one spot

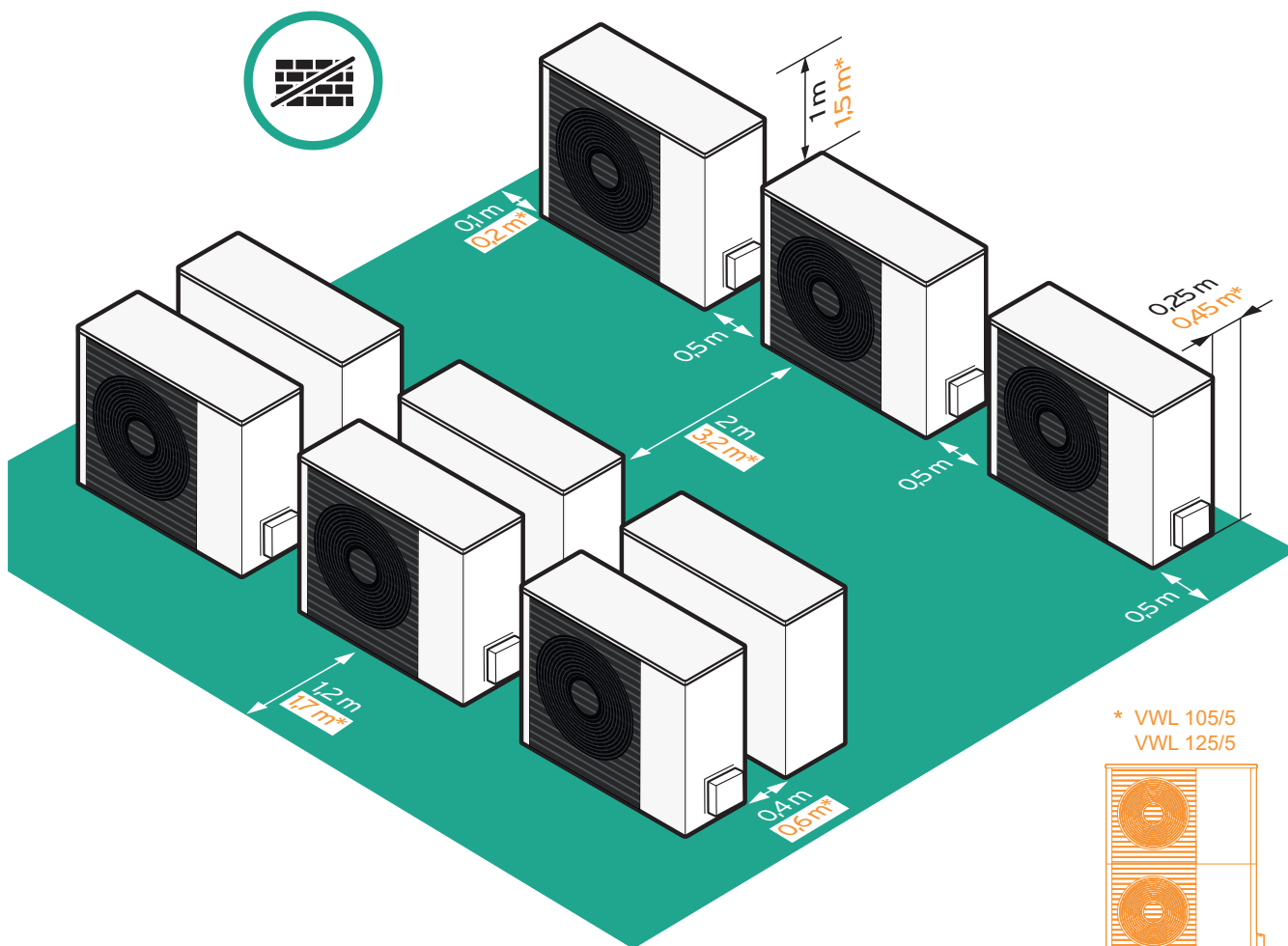

Maximum height difference between indoor and outdoor unit

Outdoor unit above indoor unit

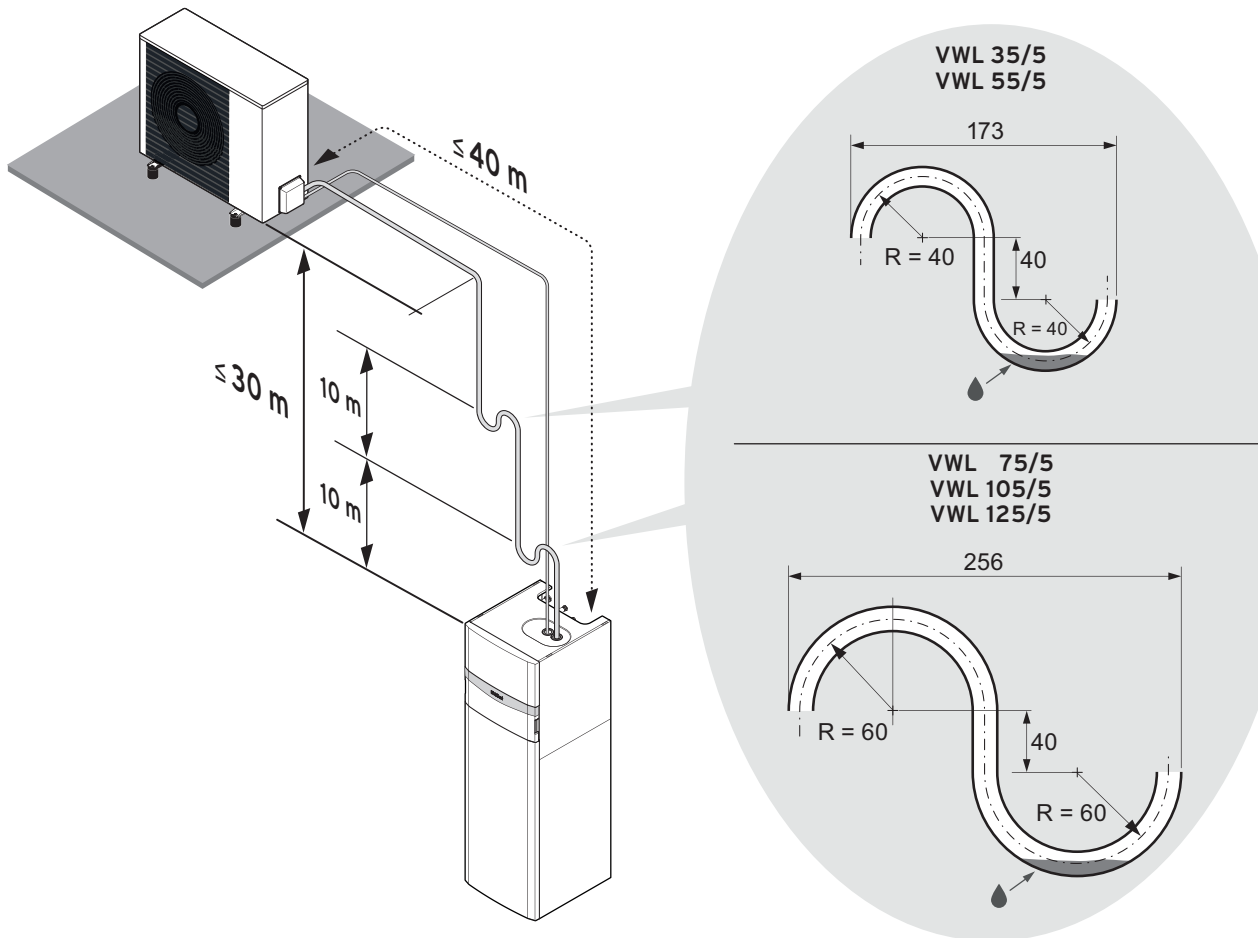

Outdoor unit below indoor unit

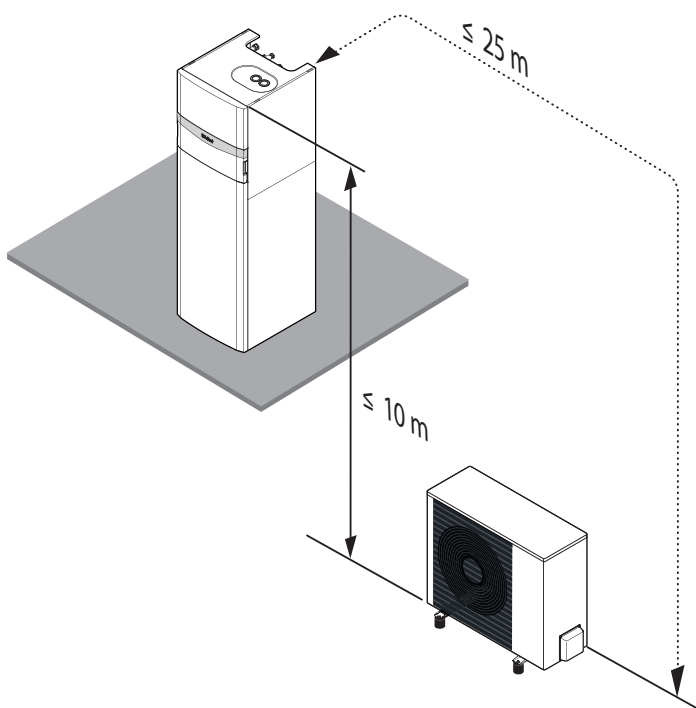

Select the perfect domestic hot water and buffer storage

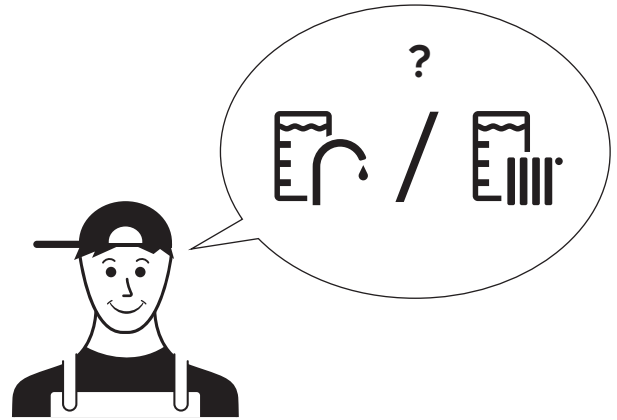
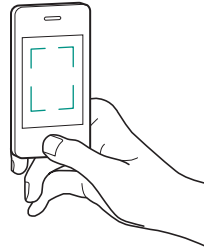

Scan the QR code to quickly calculate the required storage volume

Storage heated up by heat pump only					... heat pump and solar heat	
Storage	uniTOWER ../5 IS	uniSTOR VIH RW 200	uniSTOR VIH RW 300	uniSTOR VIH RW 400	uniSTOR VIH RW 500	uniSTOR VIH SW 400	uniSTOR VIH SW 500
Capacity heated up by the heat pump	190 l	200 l	300 l	400 l	500 l	200 l	250 l
Tap capacity with 38 °C at 55 °C inside the storage	305 l	321 l	482 l	643 l	804 l	321 l	402 l
aroTHERM split	Time to reheat storage to 55°C without backup heater, once temperature falls below 46°C at 7°C outdoor temperature						
VWL 35/5	31 min	32 min	48 min	64 min *	80 min *	32 min	40 min
VWL 55/5	24 min	25 min	37 min	49 min	62 min *	25 min	31 min
VWL 75/5	18 min	19 min	29 min	38 min	48 min	19 min	24 min
VWL 105/5	15 min	16 min	24 min	31 min	39 min	16 min	20 min
VWL 125/5	15 min	16 min	24 min	31 min	39 min	16 min	20 min

* Limited comfort -> We recommend to select the aroTHERM split next in size.

Minimum required buffer/ water volume for deicing

aroTHERM split	With active backup heater, system temperature > 25°C	Without active backup heater, system temperature > 15°C
VWL 35/5, VWL 55/5	15 l	40 l
VWL 75/5	20 l	55 l
VWL 105/5, 125/5	45 l	150 l

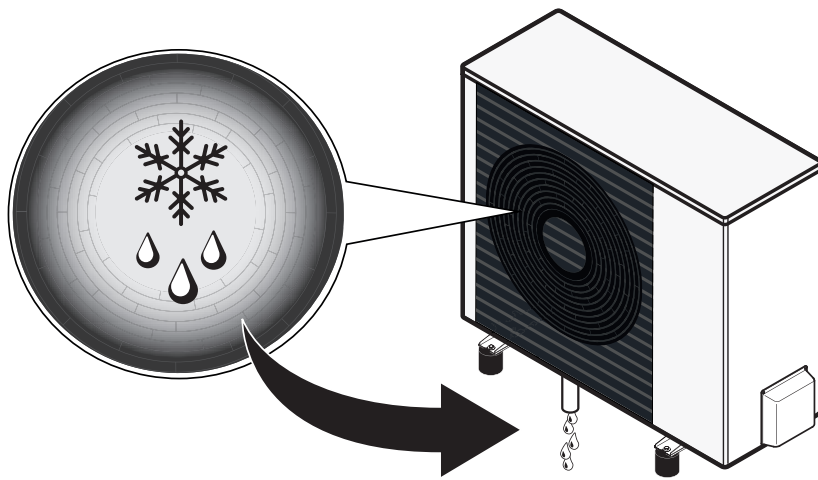

Dimension the expansion vessel

Scan the QR code to easily dimension your expansion vessel

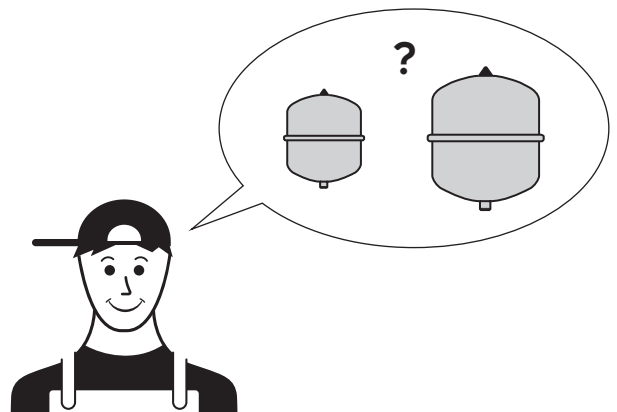
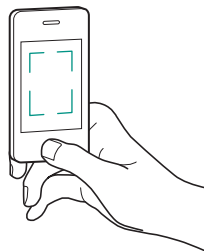

Scan or Click QR-Code for dimensions
of the expansion vessel

Remaining pressure head of heating circuit pump

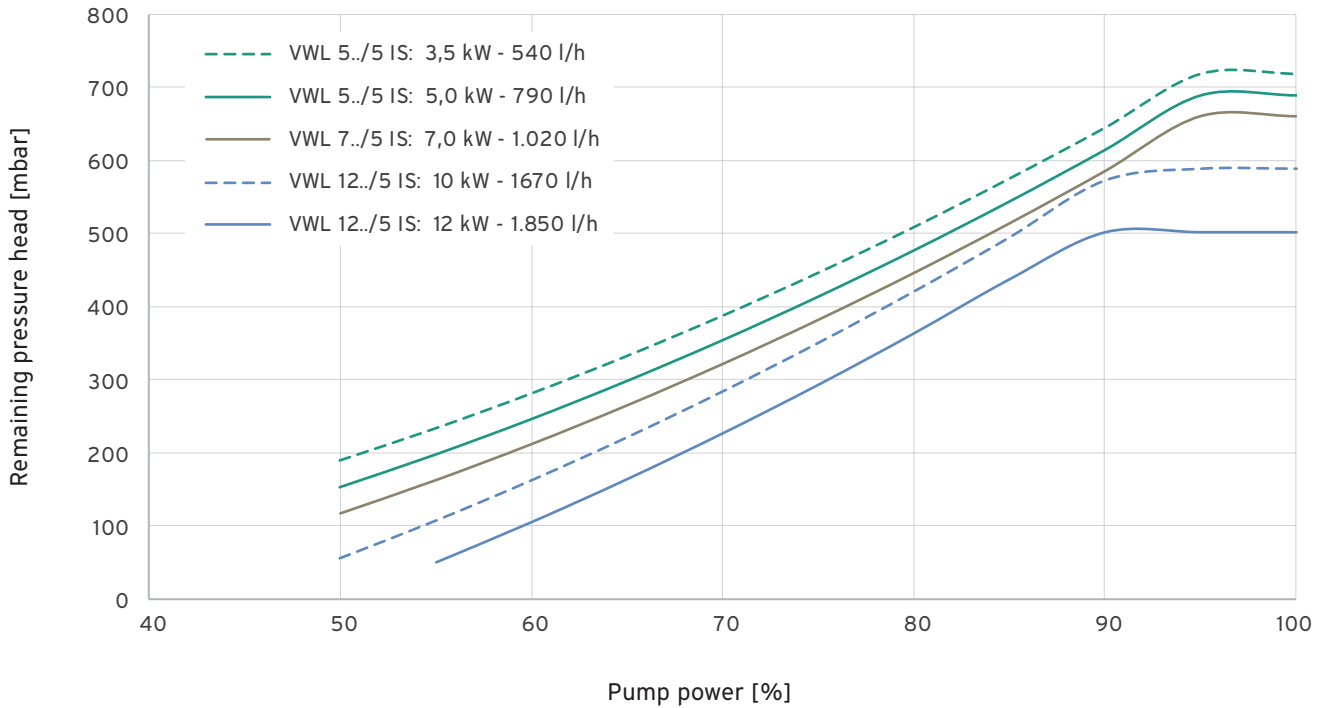

Select your system scheme (system components, hydraulics and wiring)

Scan the QR code to select a system scheme from our broad data base

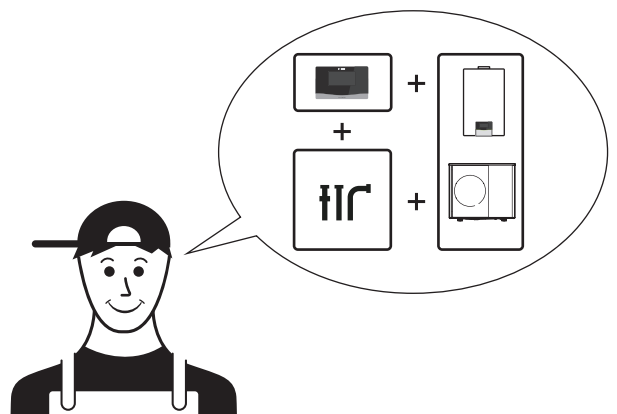
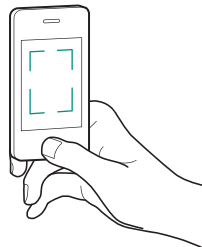

Scan or Click QR-Code to select system scheme

Decide on the installation type

On the roof ...

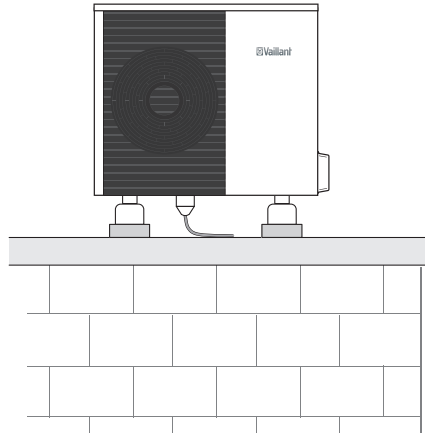



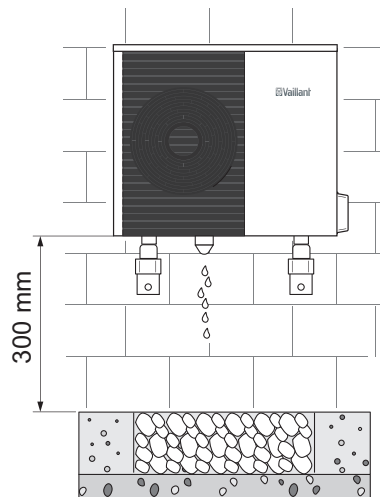



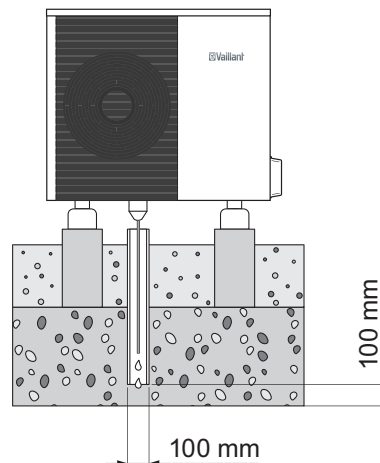

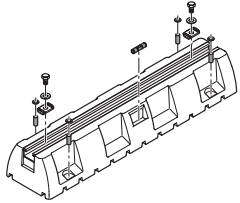

On the wall ...

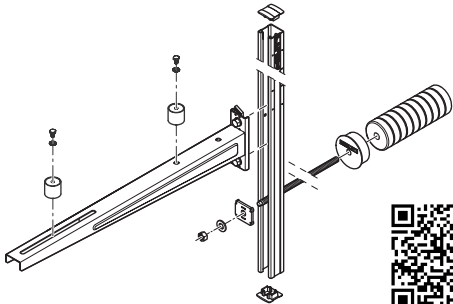

On the ground ...

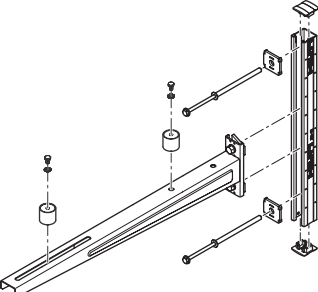

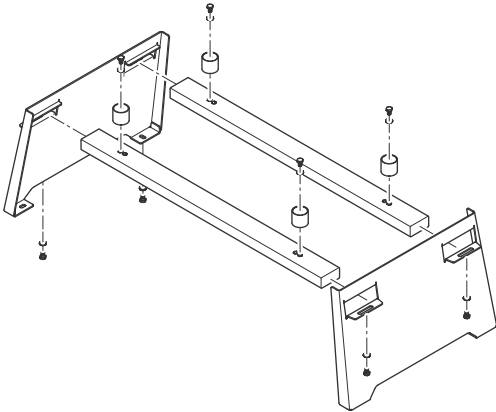
Select mounting accessories

	Installation option	
	Ground/Roof	Wall
Mounting		
Simple	<p>Big rubber feet Art.-No.: 0020250226</p>   <p>Small rubber feet Art.-No.: 0020252091</p>  	<p>Wall brackets for insulated walls Art.-No.: 0020250224</p>   <p>Wall brackets for non-insulated walls Art.-No.: 0020250225</p>  
Snow	<p>Snow spacer Art.-No.: 0020173403</p>  	

Select refrigerant pipes

aroTHERM split	Connection type and Installation accessories		
	Distance between outdoor unit and indoor unit		
	up to 5 m	5 m to 10 m	up to 25 m
VWL 35/5 VWL 55/5	<p>Twin tubes including eBUS, 5 m (1/4" + 1/2")</p> <p>Art.-No: 0020250307</p>	<p>Twin tubes including eBUS, 10 m (1/4" + 1/2")</p> <p>Art.-No: 0020250308</p>	<p>Refrigerant pipe, 25 m (1/4")</p> <p>Art.-No: 0020250311</p> <p>+</p> <p>Refrigerant pipe, 25 m (1/2")</p> <p>Art.-No: 0020250312</p>
VWL 75/5 VWL 105/5 VWL 125/5	<p>Twin tubes including eBUS, 5 m (3/8" + 5/8")</p> <p>Art.-No: 0020250305</p>	<p>Twin tubes including eBUS, 10 m (3/8" + 5/8")</p> <p>Art.-No: 0020250306</p>	<p>Refrigerant pipe, 25 m (3/8")</p> <p>Art.-No: 0020250309</p> <p>+</p> <p>Refrigerant pipe, 25 m (5/8")</p> <p>Art.-No: 0020250310</p>

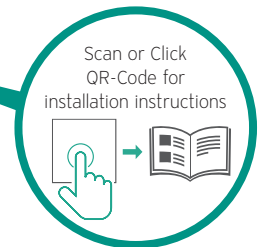
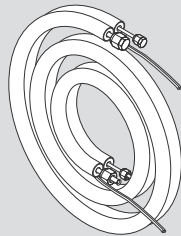

Check your plan!

Tick your planning checklist 

- Heat pump depending on the heating and cooling load calculation chosen
- Installation site planned (quiet, vented)
- System temperatures chosen (underfloor, radiator, fan coil)
- Domestic hot water and buffer tank chosen
- Expansion vessel determined
- System scheme selected
- System components incl. accessories for installation ordered



... work your Plan

Install the aroTHERM split system.

Start with the hydraulic installation

Realize the condensate drain

Do! 

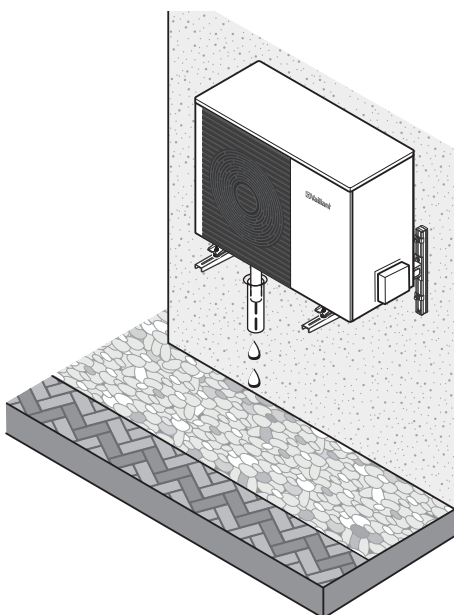
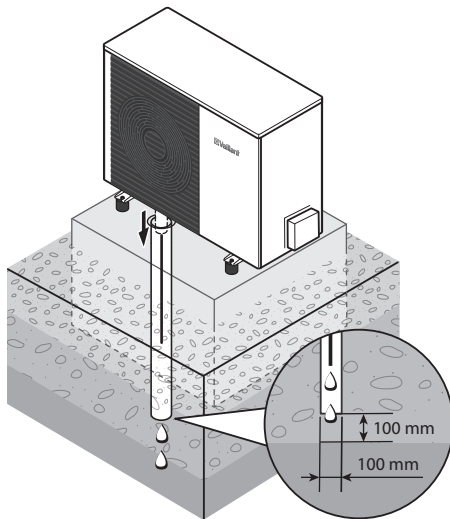

Don't 

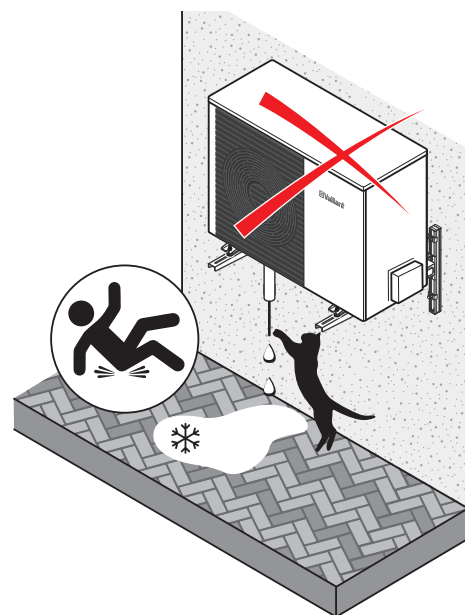
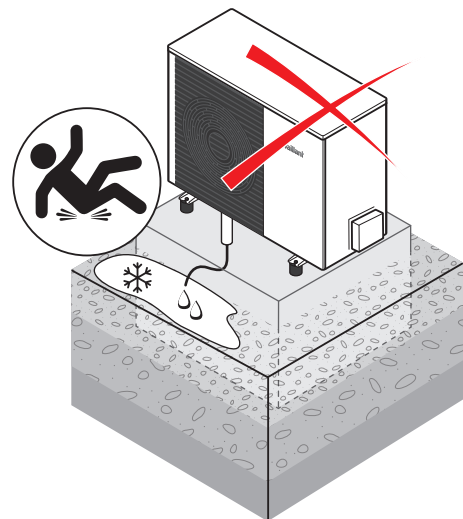

Realize the quietest installation

Origin of vibrations

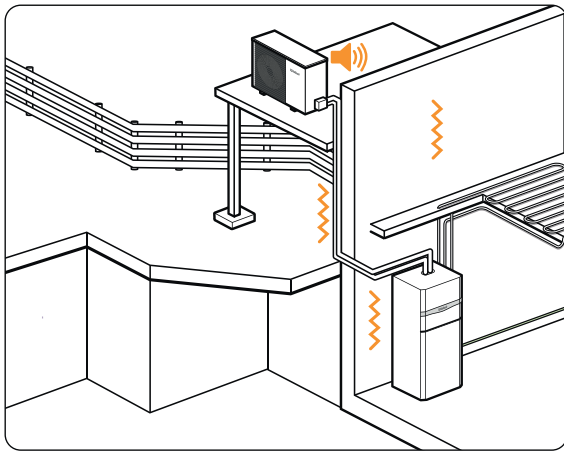
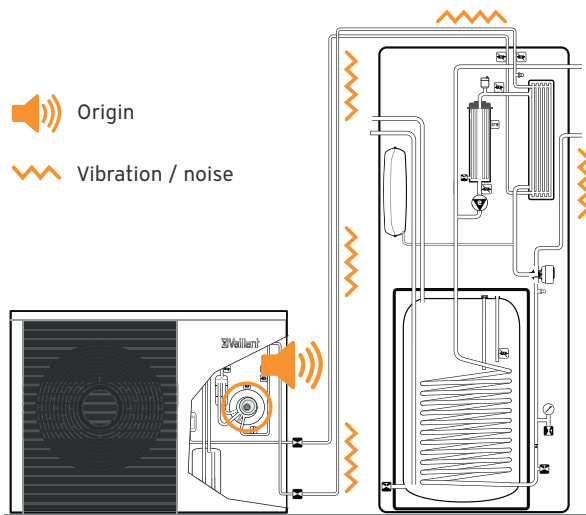

Avoid kinks in the pipe

Do!



Don't!

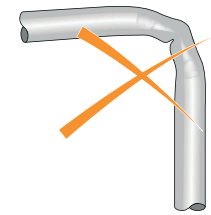

How to minimize vibrations

Fix refrigerant pipes with appropriate refrigerant clamps

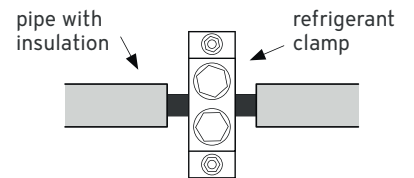
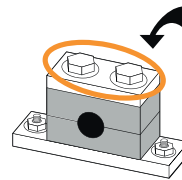

OR

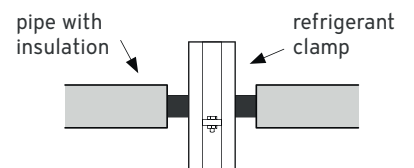
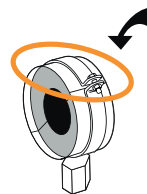

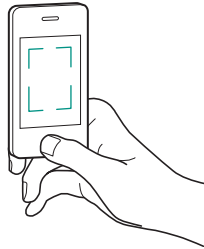

Connect the refrigerant pipes

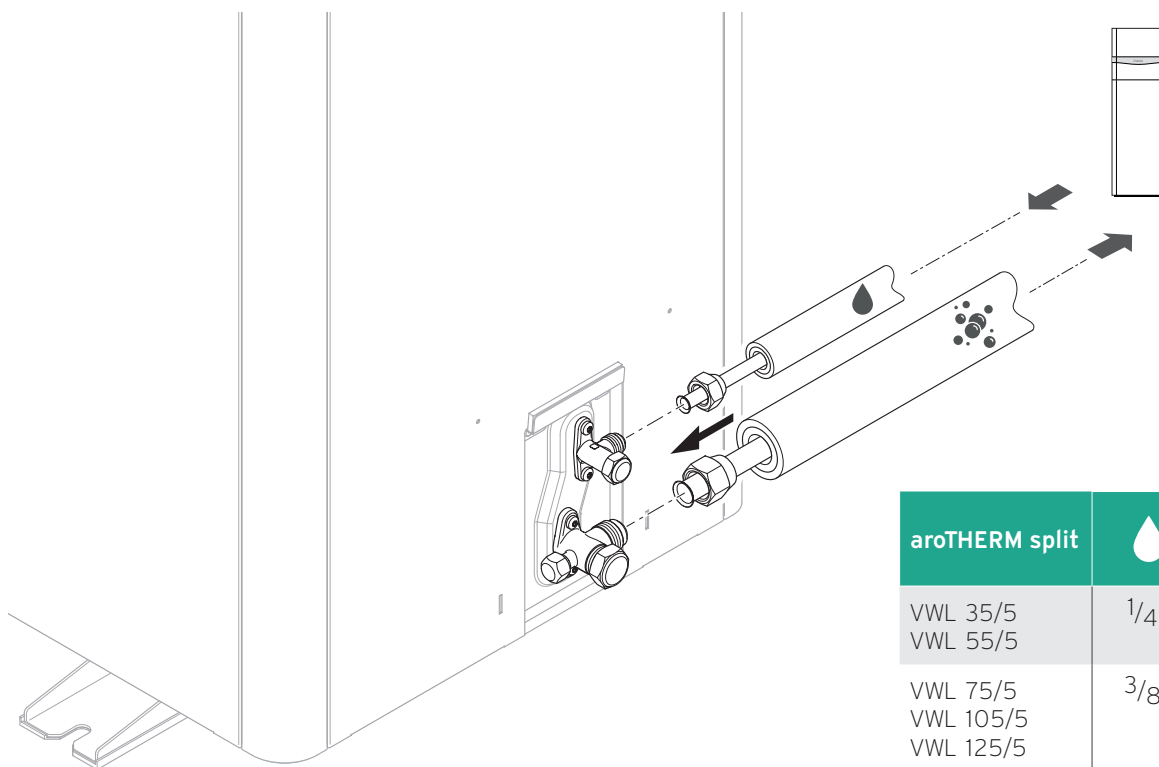

Scan or Click QR-Code for installation video



aroTHERM split		
VWL 35/5 VWL 55/5	1/4"	1/2"
VWL 75/5 VWL 105/5 VWL 125/5	3/8"	5/8"

Proceed to the power supply and eBUS connection

Calculate the cable cross section

Scan the QR-Code to easily calculate the required cable cross section for the wiring

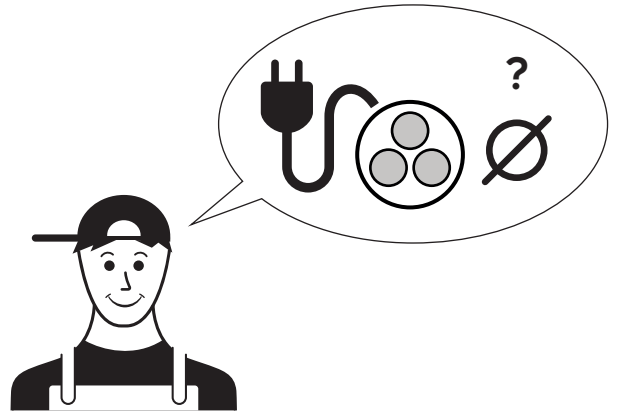
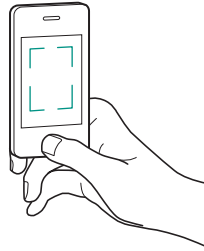

Scan or Click QR-Code
for calculating the cable cross section

Preparation

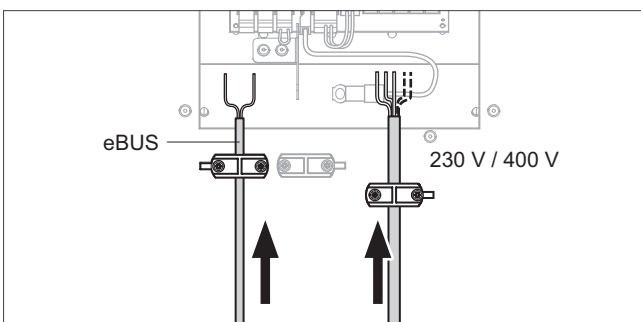
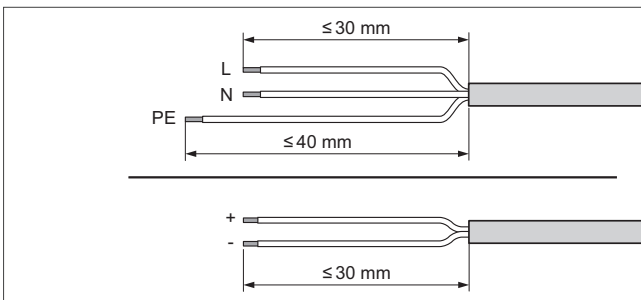
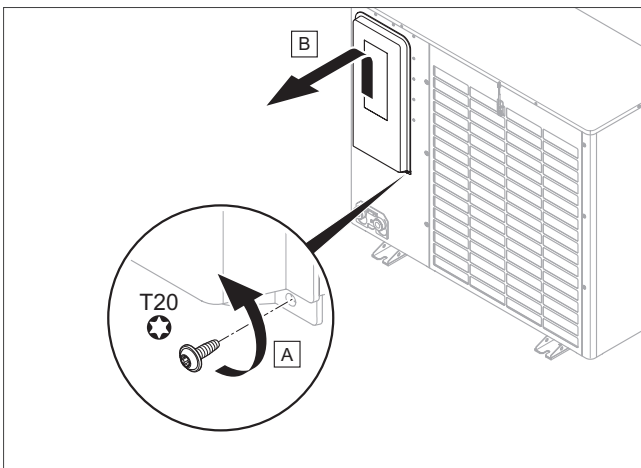

Power supply connection (230 V / 400 V)

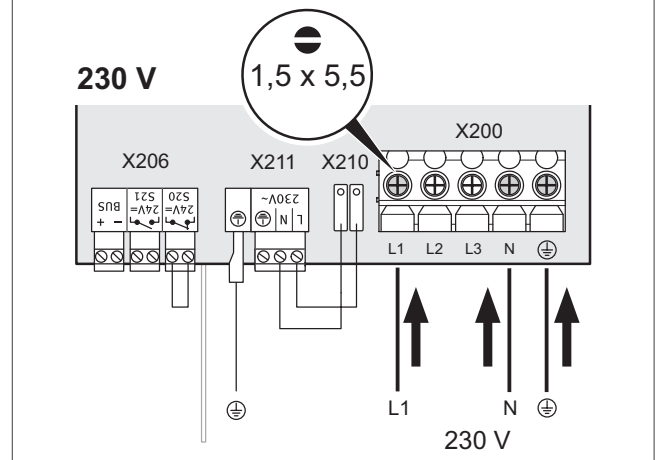
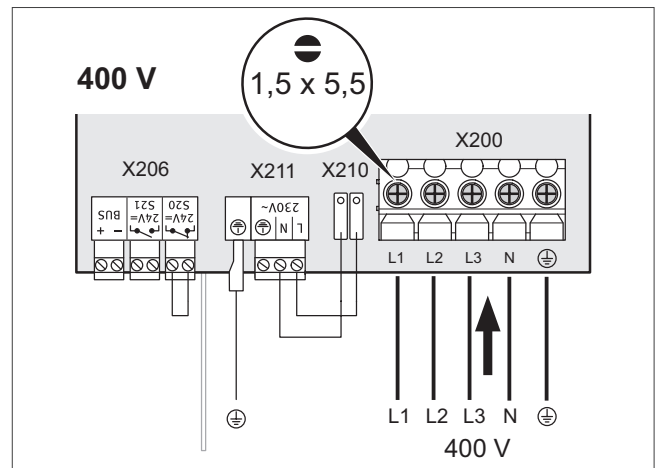

eBUS connection

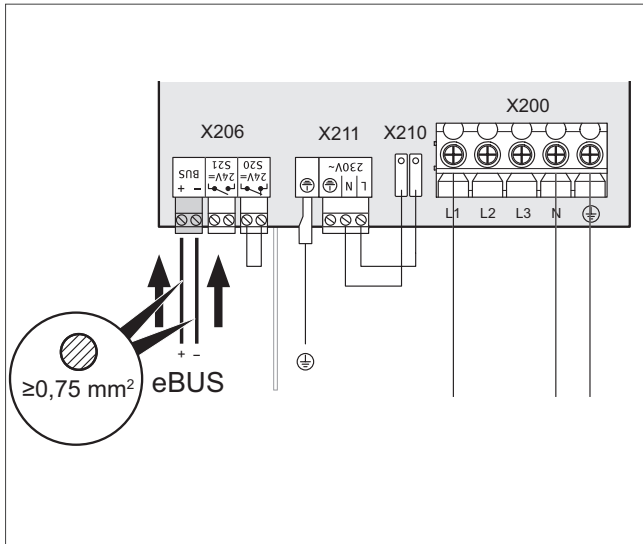

Fasten cable strain reliefs

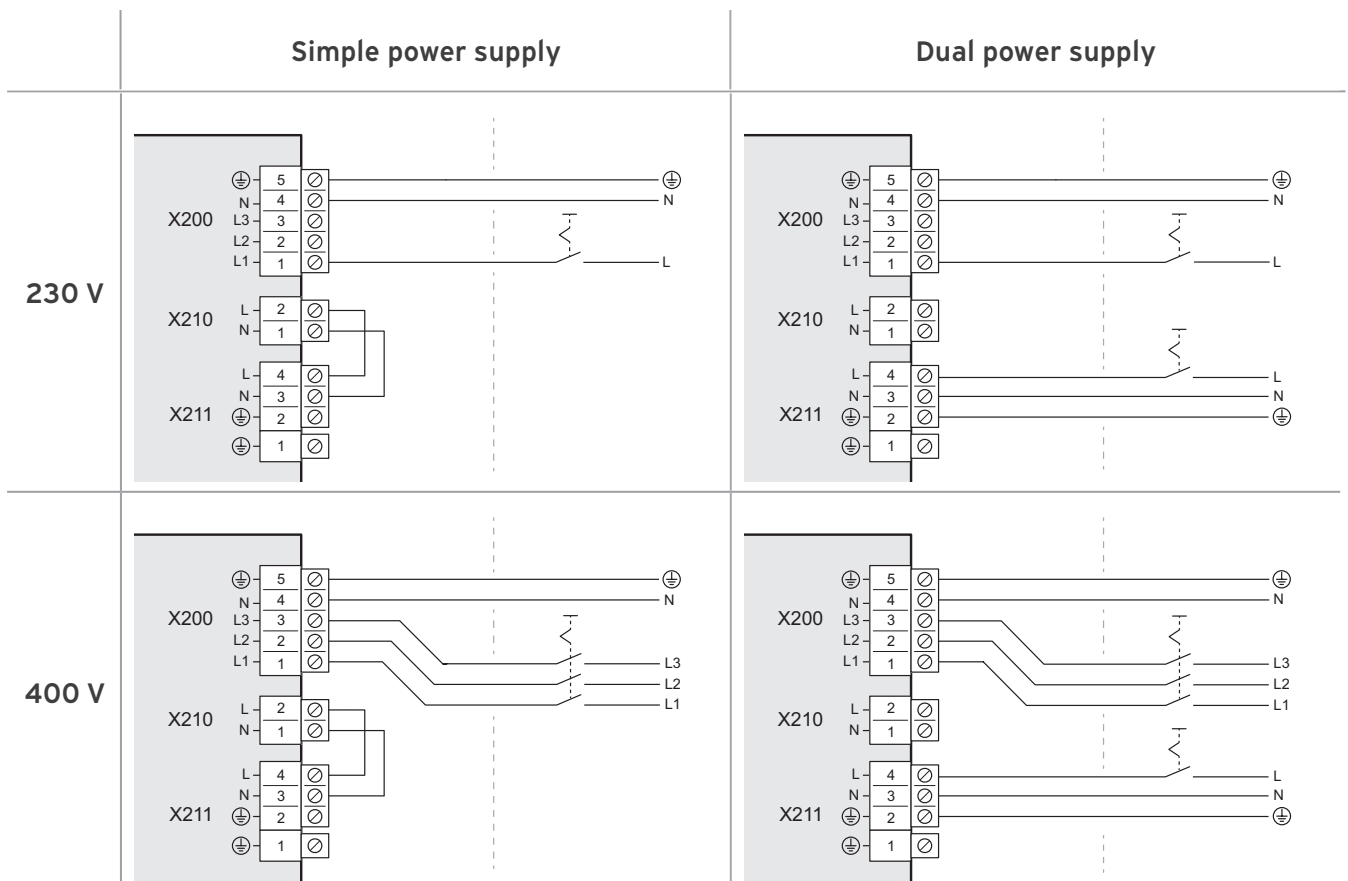
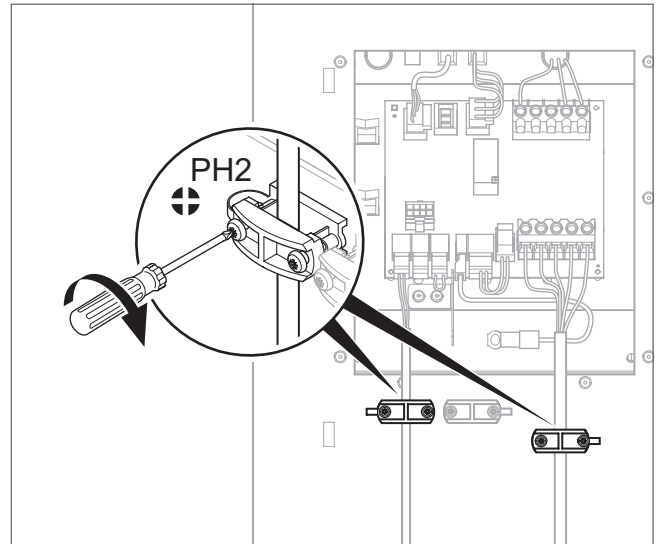

Connect the uniTOWER or hydraulic module

Install the uniTOWER

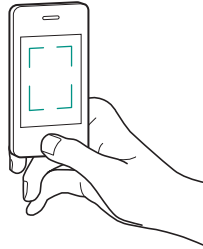



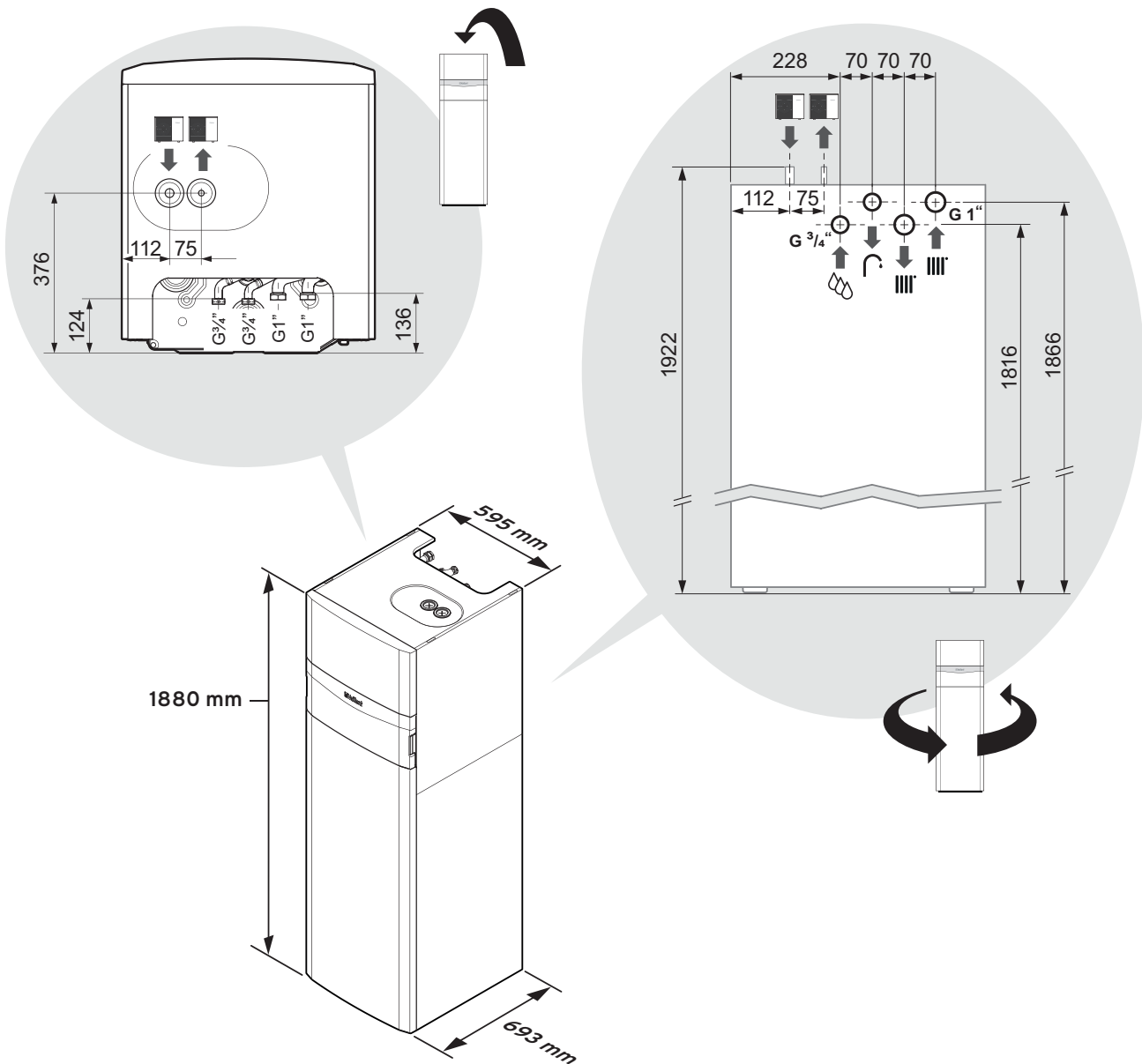







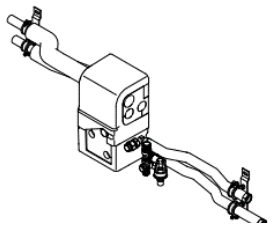

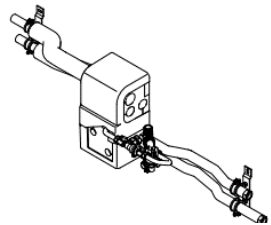

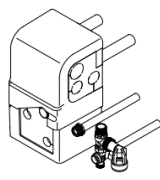

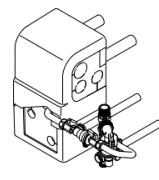

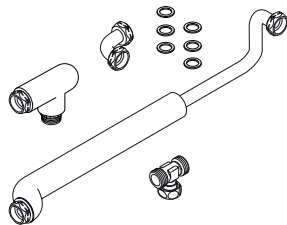
Scan or Click QR-Code for installation video

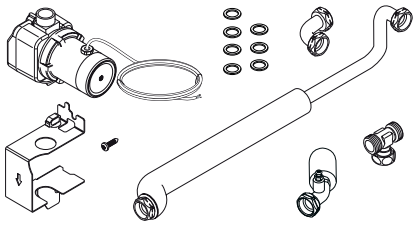

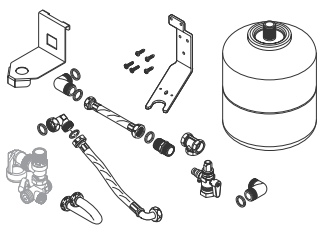
Click on images for installation instructions

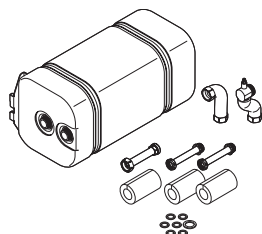

Select hydraulic accessories for the uniTOWER

Connection kit	without filling	with filling
On-wall	uniTOWER connection kit, on-wall Art.-No.: 0020250219  	uniTOWER connection kit, on-wall with filling Art.-No.: 0020250221  
In-Wall	uniTOWER connection kit, in-wall Art.-No.: 0020250220  	uniTOWER connection kit, in-wall with filling Art.-No.: 0020250222  
Circulation	without pump Circulation pipe set Art.-No.: 0020170502  	with pump Circulation pump set Art.-No.: 0020170503  
Domesitc hot water expansion vessel		
	DHW expansion vessel back Art.-No.: 0020180979  	DHW expansion vessel front Art.-No.: 0020170500  
Additional system components		
	18l Buffer tank for uniTOWER Art.-No.: 0020269273  	

Install the hydraulic module

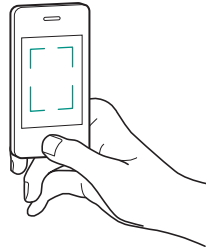

Scan or Click QR-Code for installation video

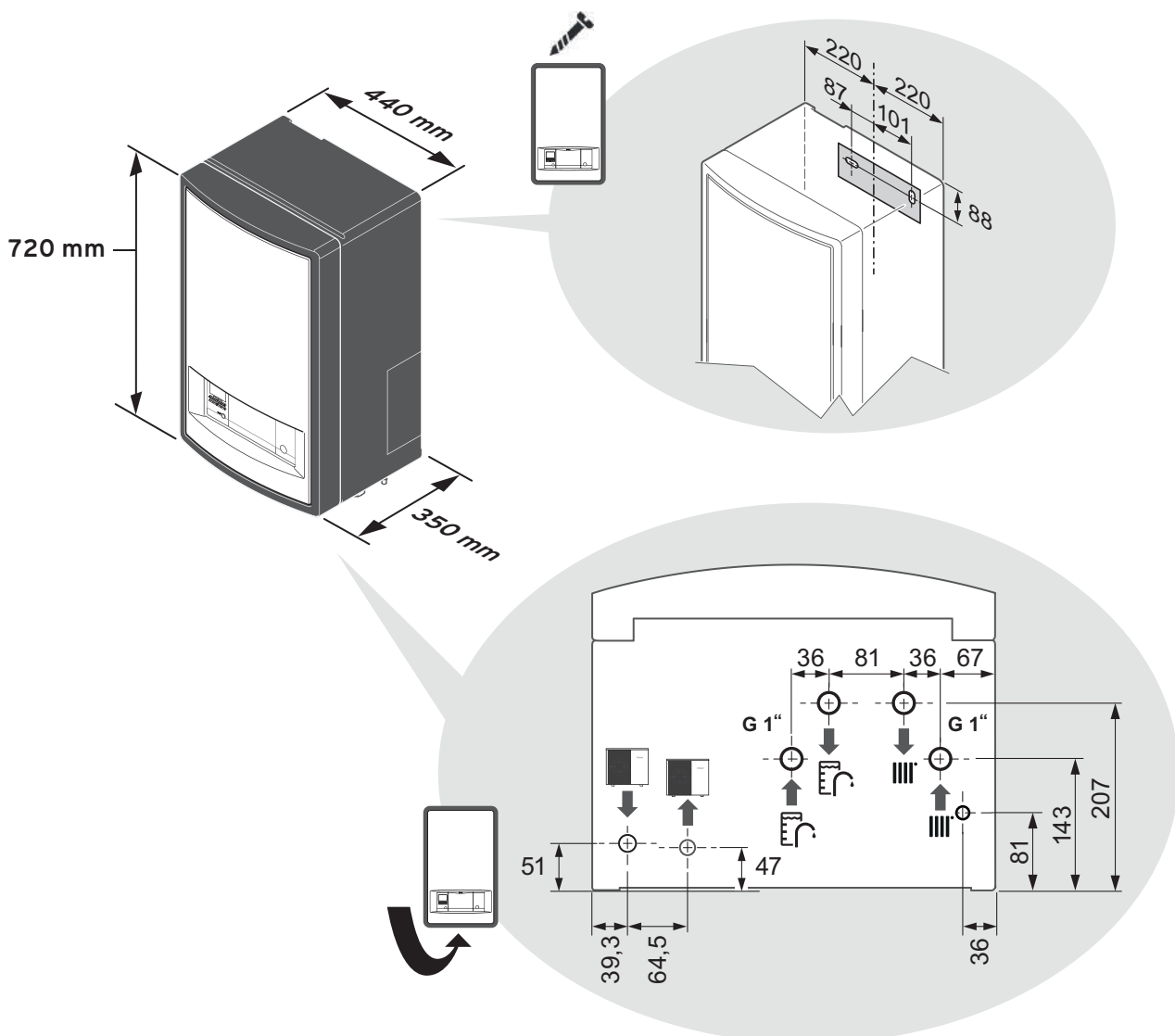

Commission the refrigerant circuit

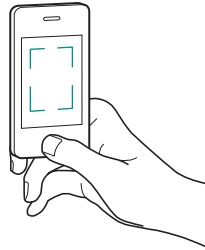

Scan or Click QR-Code for installation video

Amount of refrigerant to be filled up

—●— VWL 35/5
—●— VWL 55/5
 —●— VWL 75/5
 —●— VWL 105/5 (230 V/400 V)
—●— VWL 125/5 (230 V/400 V)

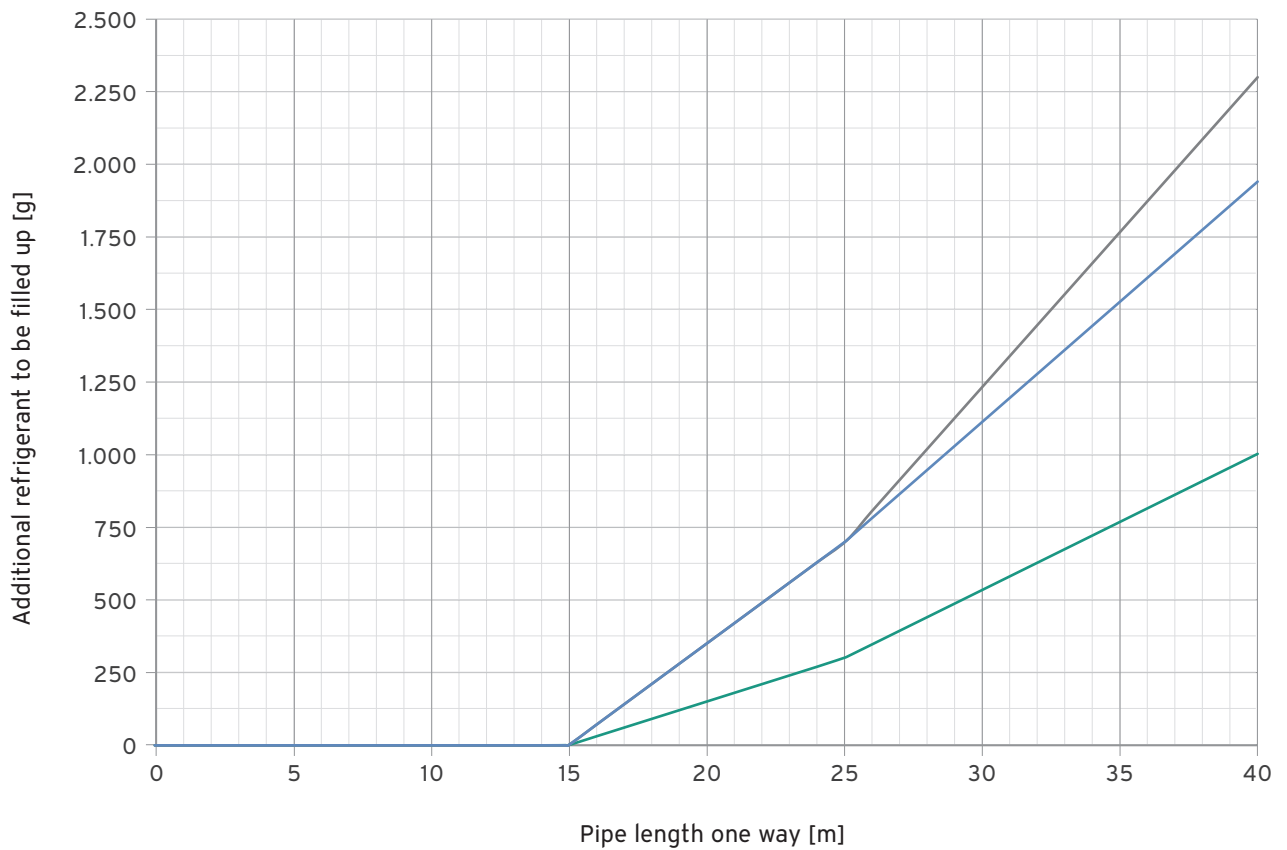

Check your installation!

Tick your installation checklist 

- Heat pump positioned according to type of installation (ground, wall, roof)
- Refrigerant pipes bent and connected
- Tightness of refrigerant circuit checked
- Refrigerant circuit evacuated
- Optional: Additional refrigerant filled up
- Refrigerant released from outdoor unit into refrigerant circuit
- Safety valve installed
- Expansion vessel installed and connected
- Manometer installed
- All valves installed in system
- Hydraulic connected and tight (pressure test performed)
- Wiring connection done
- Heating system vented
- Optional: Warranty extension/ maintenance and service contract signed

... and start your System

Scan the QR code to easily set up the system ...



Just in case ...

Find remedies to error, status and maintenance codes

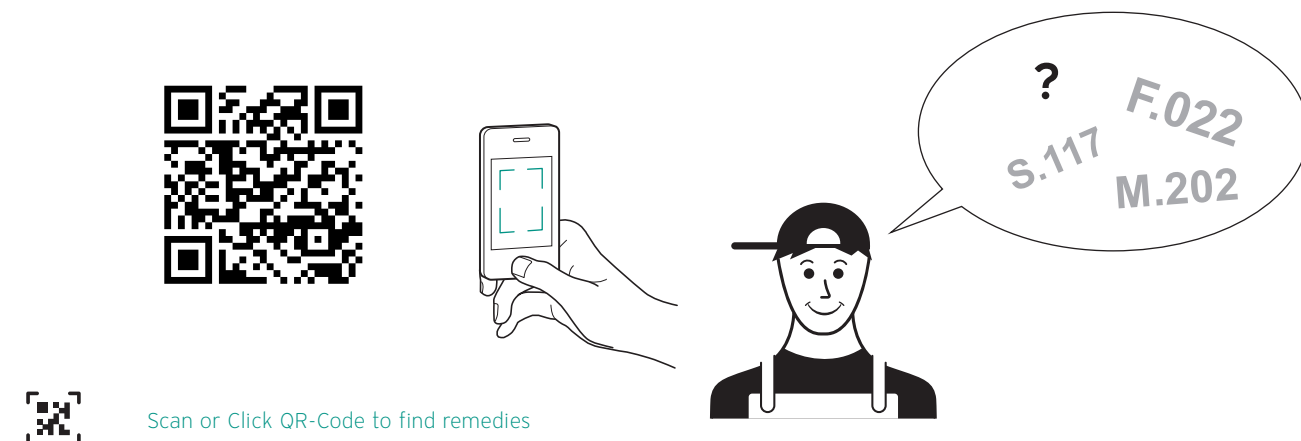

Technical Data - aroTHERM split

aroTHERM split	VWL 35/5 AS	VWL 55/5 AS	VWL 75/5 AS	VWL 105/5 AS	VWL 105/5 AS	VWL 125/5 AS	VWL 125/5 AS
Rated voltage (+10%/- 15%), 50 Hz	230 V 1~/N/PE			230 V 1~/N/PE	400 V 3~/N/PE	230 V 1~/N/PE	400 V 3~/N/PE
Rated power, maximum	2,96 kW	2,96 kW	3,84 kW	4,90 kW	7,60 kW	4,90 kW	7,60 kW
Rated power factor	1						
Rated current, maximum	11,5 A	11,5 A	14,9 A	21,3 A	13,5 A	21,3 A	13,5 A
In-rush current	11,5 A	11,5 A	14,9 A	21,3 A	13,5 A	21,3 A	13,5 A
IP rating	IP 15 B						
Refrigerant circuit							
Max. height difference when outdoor unit is above indoor unit	30 m						
Max. length of refrigerant pipe when outdoor unit is above indoor unit	40 m						
Max. height difference when indoor unit is above outdoor unit	10 m						
Max. length of refrigerant pipe when indoor unit is above outdoor unit	25 m						
Refrigerant, fill quantity	1,50 kg	1,50 kg	2,39 kg	3,60 kg			
Heating output / Cooling output							
A-7/W35	3,56 kW	4,88 kW	6,68 kW	10,15 kW	11,80 kW		
A2/W35	2,46 kW	3,37 kW	4,51 kW	8,20 kW	8,23 kW		
A7/W35	3,13 kW	4,42 kW	5,78 kW	9,70 kW	10,25 kW		
A7/W45	3,05 kW	4,04 kW	5,47 kW	9,06 kW	9,60 kW		
A7/W55	2,73 kW	3,69 kW	4,95 kW	10,35 kW	10,90 kW		
A35/W7 (cooling)	3,12 kW	3,12 kW	4,40 kW	8,69 kW	8,69 kW		
A35/W18 (cooling)	4,83 kW	4,83 kW	6,30 kW	12,78 kW	12,78 kW		
Coefficient of performance COP, EN 14511 (heating) / Energy efficiency ratio EER, EN 14511 (cooling)							
A-7/W35	3,11	2,67	2,64	2,78	2,46		
A2/W35	3,75	3,67	3,68	3,87	3,69		
A7/W35	4,89	4,68	4,58	4,57	4,61		
A7/W45	3,54	3,49	3,57	3,49	3,53		
A7/W55	2,62	2,67	2,69	2,77	2,78		
A35/W7 (cooling)	2,69	2,69	2,8	2,49	2,59		
A35/W18 (cooling)	3,76	3,76	3,58	3,28	3,36		
Power consumption, effective							
A-7/W35	1,15 kW	1,83 kW	2,53 kW	3,65 kW	4,81 kW		
A2/W35	0,66 kW	0,92 kW	1,23 kW	2,12 kW	2,26 kW		
A7/W35	0,64 kW	0,95 kW	1,26 kW	2,12 kW	2,26 kW		
A7/W45	0,86 kW	1,16 kW	1,53 kW	2,60 kW	2,75 kW		
A7/W55	1,05 kW	1,38 kW	1,84 kW	3,74 kW	3,94 kW		
A35/W7 (cooling)	1,16 kW	1,16 kW	1,57 kW	3,49 kW	3,49 kW		
A35/W18 (cooling)	1,29 kW	1,29 kW	1,76 kW	3,90 kW	3,90 kW		
Power consumption							
A-7/W35	5,40 A	8,60 A	11,80 A	17,40 A	5,70 A	22,70 A	7,50 A
A2/W35	3,20 A	4,40 A	5,50 A	10,20 A	3,30 A	10,50 A	3,40 A
A7/W35	3,20 A	4,60 A	5,80 A	9,90 A	3,20 A	10,50 A	3,50 A
A7/W45	4,10 A	5,40 A	6,80 A	12,00 A	4,10 A	12,70 A	4,30 A
A7/W55	4,90 A	6,30 A	8,00 A	17,00 A	5,80 A	18,30 A	6,20 A
A35/W7 (cooling)	5,40 A	5,40 A	7,30 A	15,50 A	5,10 A	15,50 A	5,10 A
A35/W18 (cooling)	6,00 A	6,00 A	7,90 A	17,40 A	5,90 A	17,40 A	5,90 A
Sound power, EN12102, EN ISO 9614-1							
A7/W55	53 dB(A)	54 dB(A)	54 dB(A)	60 dB(A)	60 dB(A)	60 dB(A)	60 dB(A)
A-7/W35	46 dB(A)	46 dB(A)	48 dB(A)	53 dB(A)	55 dB(A)	53 dB(A)	55 dB(A)
A35/W18 (cooling)	54 dB(A)	54 dB(A)	56 dB(A)	59 dB(A)	59 dB(A)	59 dB(A)	59 dB(A)

Technical Data - uniTOWER

	VWL 58/5 IS	VWL 78/5 IS	VWL 128/5 IS
Rated voltage 230 V (+10%/- 15%), 50 Hz	230 V 1~/N/PE		
Rated voltage 400 V (+10%/- 15%), 50 Hz	400 V 3~/N/PE		
Rated power, maximum	5,4 kW	5,4 kW	8,8 kW
Rated current, maximum , 230 V	23,5 A		
Rated current, maximum , 400 V	14,5 A		
IP rating	IP 10 B		
Heating circuit			
Heating water temperature, minimum/ maximum	20 ... 55 °C		
Water content	16,6 l	17,1 l	17,6 l
Operating pressure, minimum	0,05 MPa (0,50 bar)		
Operating pressure, maximum	0,30 Mpa (3,00 bar)		
Domesitc hot water circuit			
Water capacity hot water tank	185 l		
Cylinder temperature by heat pump max.	57 °C		

Technical Data - hydraulic module

	VWL 57/5 IS	VWL 77/5 IS	VWL 127/5 IS
Rated voltage 230 V (+10%/- 15%), 50 Hz	230 V 1~/N/PE		
Rated voltage 400 V (+10%/- 15%), 50 Hz	400 V 3~/N/PE		
Rated power, maximum	5,4 kW	5,4 kW	8,8 kW
Rated current, maximum , 230 V	23,5 A		
Rated current, maximum , 400 V	14,5 A		
IP rating	IP 10 B		
Heating circuit			
Heating water temperature, minimum/maximum	20 ... 55 °C		
Operating pressure, minimum	0,05 MPa (0,50 bar)		
Operating pressure, maximum	0,30 Mpa (3,00 bar)		



Vaillant GmbH

Berghauser Str. 40 ■ D-42859 Remscheid
Tel. +49 21 91 18-0 ■ Fax +49 21 91 18-28 10
www.vaillant.de ■ info@vaillant.de